

Analysis of the Influence of Variables on the Self-Reliance of Kyrgyzstan Residents: Application of the Decision Tree Analysis Method

Authors: Young-Chool Choi (Professor, Department of Public Administration, Chungbuk National University, Korea), Jungsun Choi (KOICA Young Professional, Korea) and Jinsaem Lee (KOICA Young Professional, Korea)

Corresponding author: ycchoi@cbu.ac.kr

Summary

The aim of this study is to measure the degree of self-reliance of local residents in Kyrgyzstan. The study draws on the results of a baseline survey for implementing an aid project for rural development, which is being carried out in Kyrgyzstan in collaboration with Korea's Good Neighbours International (GNI) and Korea International Cooperation Agency (KOICA). In this study, a decision tree analysis was performed to analyse the level of self-reliance of Kyrgyzstan residents, along with the combination of variables that affect self-reliance.

Keywords: Kyrgyz ODA, independence, decision tree analysis, GNI, KOICA.

1 Introduction

Numerous factors affect people's quality of life. They include institutional factors such as the capacity of the government, but individual characteristics, such as the independence of each individual, also act as important factors in determining individuals' standards of living (Agusty & Damayanti, 2015; Asiana & Quartey, 2009; Borensztein et al., 1998; Hsiao & Shen, 2003; Jones & Mendizabal, 2010; Elistia & Syahzuni, 2018; Wang et al., 2018). Even when developed countries successfully promote Official Development Assistance (ODA) projects that support developing countries, not only do they need to consider the institutional capabilities of aid-recipient countries, but they also need to pay attention to factors such as the personal character and willingness of aid recipients. Korea's per capita GDP in 1960 was only 92 US\$, but the speed with which it has achieved economic development is unprecedented.

As a result, by 2022 Korea was among the world's top ten economies, and its successful cases and experiences of development are now passed on to developing countries. Korea was a recipient of foreign aid from the mid-1950s up until 1999, but has now become a donor country. South Korea is the only country in the world that has switched from being an aid recipient to an aid donor. Although the role of government officials, including the president, was a major factor in Korea's rapid economic growth, the strong self-reliance of the people also acted as an important factor. In line with the case of Korea, many scholars (Hsiao & Shen, 2003; Jones & Mendizabal, 2010; Elistia & Syahzuni, 2018) agree that the level of self-reliance of the people acts as an important factor influencing national development.

Against this background, this study aims to measure the level of self-reliance of a specific group of local residents in Kyrgyzstan in Central Asia, and analyse the factors that affect this. To this end, Good Neighbours International (GNI), a private Korean organization, along with Korea International Cooperation Agency (KOICA), the Korean government's aid execution agency, investigated the self-reliance of these residents in the process of conducting rural development projects in Kyrgyzstan, and we analyse here the results of this investigation. The official name of this project is the Integrated Rural Development Project in Kyrgyz Republic. This project is ongoing, carried out by GNI as part of KOICA's public-private partnership programme for co-operation with civil society under the so-called 'Strategic Partner Project'. Its purpose is to develop the rural areas of the Kyrgyz Republic in an integrated manner, and the project period runs from 14 September 2021 to 31 December 2025. The cost is around 10.6 billion won (c. 9 million US\$). The target areas are the Osh Oblast and Batken Oblast regions of Kyrgyzstan, and thirty villages in these two regions are included in the project targets.

As stated above, the aim of this study is to measure the levels of self-reliance of the local residents of Kyrgyzstan and to analyse the relationship between the variables that affect this. Thereby, we aim to discover the influencing factors that can help such residents increase their acceptance of ODA policies, and increase the success potential of ODA projects when carrying these out in the future.

2 Theoretical Discussion and Research Problems

How may self-reliance be defined? Self-reliance can be defined in many ways (Asiama & Quartey, 2009; Borensztein et al., 1998; Hsiao & Shen, 2003; Jones & Mendizabal, 2010; Elistia & Syahzuni, 2018). Generally speaking, it may be defined as being in control of one's life while choosing acceptable options that minimize one's dependence on others in one's decision-making and daily life. In short, embracing self-reliance is tied to control. In other words, the question 'How self-reliant are you?' is related to the question 'Under whose rule are you, and to what extent?'. Self-control in relation to oneself, one's relationships, and one's surrounding environment is at the core of the concept of independent living.

The major sub-concepts emphasized by self-reliant living include self-direction, empowerment, self-help, involvement in community activities and environmental change (Hummelbrunner, 2010; Asiama & Quartey, 2009; Hussain, 2013; Borensztein et al., 1998; Hsiao & Shen, 2003). These concepts can be divided into self-domination, self-determination and social environment change. Even taking into account these complexities, self-reliance can be defined simply as being in control of one's life while minimizing one's dependence on others in one's decision-making and daily life.

Why, then, is such self-reliance important in life? The reason is that residents without self-reliance harden their habit of relying on others, making it difficult for them to escape from poverty (Lee et al., 2019; Rahman & Rahman, 2014; Signor & Vandernoot, 2021). Successful countries or organizations have a strong will to become self-reliant in a short time, even if they initially receive aid or help from others, because the people, or the internal members of the organization, have a strong sense of self-reliance. In the end, even in the case of developing countries receiving aid, if their citizens' self-reliance is weak they fall into a vicious circle that solidifies the habit of continuously relying on aid from outside. For this reason, the level of self-reliance of residents in developing countries is of decisive importance in bringing about the success of ODA projects.

Many studies have addressed the factors that affect self-reliance (Asiama & Quartey, 2009; Borensztein et al., 1998; Hsiao & Shen, 2003; Jones & Mendizabal, 2010; Elistia & Syahzuni, 2018; Solow, 1956). Some studies (Jones & Mendizabal, 2010; Elistia & Syahzuni, 2018) suggest that personal factors have a strong influence on self-reliance. Others (Akinkugbe, & Yinusa, 2009; Benmamoun & Lehnert, 2013; Delahais & Toulemonde, 2012) argue that government institutions or policy factors exert a powerful influence. However, recent studies (De Mello, 1999; Funnell & Rogers, 2011; Irish Aid, 2011; ITAD, 2012; Jones, 2012; Center for Global Development, 2018) argue that variables such as trust, a type of social capital, are becoming important factors influencing individual self-reliance. Thus, considering that various factors both make up self-reliance and affect it, the following research questions were set in this study:

1. What is the level of self-reliance among the Kyrgyzstan residents we studied?
2. What is the relationship between the factors affecting the level of this self-reliance?

3 Research Design

3.1 Target area

The target areas for analysis in this study are two provinces in Kyrgyzstan, Osh and Batken, and thirty villages included in these two provinces. The local people living in these villages form an important subject for the analysis. The number of households that responded to the survey was 562, and the total number of respondents, including family members and heads of families, was 3,591. However, in this study only the heads of families formed the subject of analysis.

3.2 Survey period

This survey was conducted between March and April 2022, during the baseline survey of these two regions.

3.3 Questionnaire composition

The questionnaire used in this study was written by Professor Yang-Hoon Song, who is in charge of monitoring the ODA project in Kyrgyzstan. It consists of four sections: Section 1 covers Household Demographics, Section 2 Income Structure, Section 3 Living Expenditure and Government Support for Poverty, and Section 4 Community Activity.

3.4 Variables

The dependent variable in this study is self-reliance. However, since the concept of self-reliance is difficult to measure with a single variable, this study uses multiple indicators to measure it. As Table 1 indicates, a total of eight variables were used to measure self-reliance. The Cronbach's alpha value of these eight indicators was high, at 0.92.

Table 1 Indicators for measuring independence

		Not likely at all			Highly likely ^α	
		① ^α	② ^α	③ ^α	④ ^α	⑤ ^α ^α
4D_1 ^α	I can learn anything if I put my mind to it. ^α	① ^α	② ^α	③ ^α	④ ^α	⑤ ^α ^α
4D_2 ^α	I want to develop a way to do anything better. ^α	① ^α	② ^α	③ ^α	④ ^α	⑤ ^α ^α
4D_3 ^α	People who work hard can make a better life on their own. ^α	① ^α	② ^α	③ ^α	④ ^α	⑤ ^α ^α
		Strongly disagree			Strongly agree ^α	
		① ^α	② ^α	③ ^α	④ ^α	⑤ ^α ^α
4D_4 ^α	People who work hard will have more chances of success. ^α	① ^α	② ^α	③ ^α	④ ^α	⑤ ^α ^α
4D_5 ^α	Rather than being protected by the state, people have to work on their own to meet their living expenses. ^α	① ^α	② ^α	③ ^α	④ ^α	⑤ ^α ^α
4D_6 ^α	People have to earn a living for themselves if they can. ^α	① ^α	② ^α	③ ^α	④ ^α	⑤ ^α ^α
4D_7 ^α	It is important for children's development that parents show their children that they work hard on their own. ^α	① ^α	② ^α	③ ^α	④ ^α	⑤ ^α ^α
4D_8 ^α	People should be able to live on their own without the help of others. ^α	① ^α	② ^α	③ ^α	④ ^α	⑤ ^α ^α

By contrast, the independent variables assumed to affect self-reliance were made up of personal background variables and trust variables. Personal background variables include the respondent's gender, ethnicity, marital status, education, ability to use the Russian language, occupation, income (income per household as of 2021), and level of trust. Here, since the term 'trust' is an abstract concept, in order to measure it six indicators were configured and the overall average value obtained, as shown in Table 2. Next, respondents whose self-reliance scores were greater than average were assigned to group 2, and those whose scores were under-average were assigned to group 1. The Cronbach's alpha value of the six variables for measuring confidence level was 0.89, and this was maintained at a high level.

Table 2 Indicators for measuring trust

		Not trust at all			Highly trust ^α	
		① ^α	② ^α	③ ^α	④ ^α	⑤ ^α ^α
4C_1 ^α	How much do you generally trust your neighbors? ^α	① ^α	② ^α	③ ^α	④ ^α	⑤ ^α ^α
4C_2 ^α	How much do you generally trust people from your own ethnic or linguistic group? ^α	① ^α	② ^α	③ ^α	④ ^α	⑤ ^α ^α
4C_3 ^α	How much do you generally trust people from other ethnic or linguistic groups? ^α	① ^α	② ^α	③ ^α	④ ^α	⑤ ^α ^α
4C_4 ^α	How much do you generally trust your village leader? ^α	① ^α	② ^α	③ ^α	④ ^α	⑤ ^α ^α
4C_5 ^α	How much do you generally trust AO government to support development of your village? ^α	① ^α	② ^α	③ ^α	④ ^α	⑤ ^α ^α
4C_6 ^α	How much do you generally trust Oblast government to support development of your village? ^α	① ^α	② ^α	③ ^α	④ ^α	⑤ ^α ^α
		Strongly disagree			Strongly agree ^α	

The basic statistics regarding the indicators relating to personal background are shown in Tables 3–10.

Table 3 Respondents' gender

		Frequency	Per cent	Valid Pct.	Accumulated Pct.
Valid	Female	300	53.4	53.5	53.5
	Male	261	46.4	46.5	100.0
	Total	561	99.8	100.0	
Missing		1	.2		
Total		562	100.0		

Table 4 Respondents' ethnicity

		Frequency	Pct.	Valid Pct.	Accumulated Pct.
Valid	Kyrgyz	449	79.9	80.0	80.0
	Uzbek	106	18.9	18.9	98.9
	Tajik	1	.2	.2	99.1
	Other	5	.9	.9	100.0
	Total	561	99.8	100.0	
Missing		1	.2		
Total		562	100.0		

Table 5 Respondents' marital status

		Frequency	Pct.	Valid Pct.	Accumulated Pct.
Valid	Single	25	4.4	4.5	4.5
	Married	466	82.9	83.1	87.5
	Widowed	52	9.3	9.3	96.8
	Divorced	18	3.2	3.2	100.0
	Total	561	99.8	100.0	
Missing		1	.2		
Total		562	100.0		

Table 6 Respondents' Russian writing ability

		Frequency	Pct.	Valid Pct.	Accumulated Pct.
Valid	Easily	326	58.0	58.0	58.0
	Difficult	78	13.9	13.9	71.9
	Not at all	117	20.8	20.8	92.7
	Don't know	41	7.3	7.3	100.0
	Total	562	100.0	100.0	

Table 7 Respondents' occupation

		Frequency	Pct.	Valid Pct.	Accumulated Pct.
Valid	0	1	.2	.2	.2
	farmer	204	36.3	36.3	36.5
	self-employed	44	7.8	7.8	44.3
	labour worker	44	7.8	7.8	52.1

office worker	4	.7	.7	52.8
government employee	160	28.5	28.5	81.3
trainee/student	3	.5	.5	81.9
remittance	6	1.1	1.1	82.9
others	96	17.1	17.1	100.0
Total	562	100.0	100.0	

Table 8 Respondents' levels of education

		Frequency	Pct.	Valid Pct.	Accumulated Pct.
Valid	0	1	.2	.2	.2
	graduate study and more	94	16.7	16.9	17.1
	bachelor	79	14.1	14.2	31.2
	college	70	12.5	12.6	43.8
	secondary school	274	48.8	49.2	93.0
	primary school	4	.7	.7	93.7
	kindergarten	3	.5	.5	94.3
	others	32	5.7	5.7	100.0
	Total	557	99.1	100.0	
Missing		5	.9		
Total		562	100.0		

Table 9 Respondents' income levels per household

	N	Min.	Max.	Mean	Std.
Income 2021	495	0	960000	115985.60	124460.648
N	495				

Note. In the case of annual income, there is also 0 among 561 people.

Table 10 Respondents' levels of trust and self-reliance

	N	Min.	Max.	Mean	Std.
trust	306	1.00	5.00	3.8666	.83866
independence	306	1.00	5.00	4.6545	.55927
valid	306				

4 Analysis Results

Decision tree analysis was performed to analyse the combination of variables that affect the residents' self-reliance. The results are shown in Figure 1.

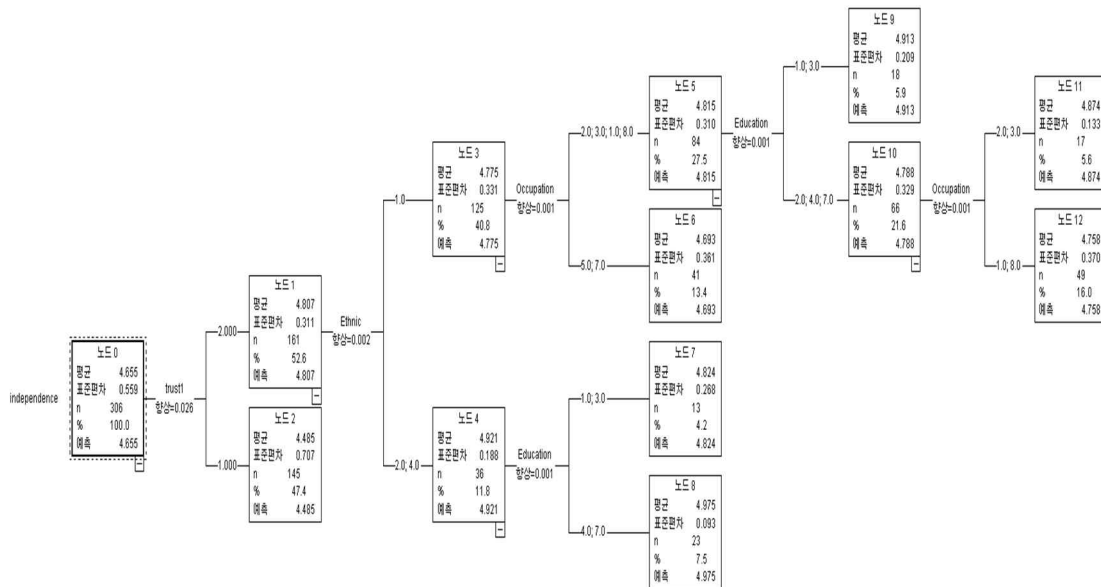

Figure 1 Results of decision tree analysis

Looking at these results, we see that all 306 respondents (n = 306) from node 0 were initially used for the analysis, and also that the average self-reliance score for these 306 persons is 4.655 and the standard deviation 0.559. It can be seen that the average score for self-reliance is relatively high, considering that the maximum value is 5. In other words, the level of self-reliance of Kyrgyzstan residents in this analysis is high. This suggests that ODA projects for Kyrgyzstan can start with a high probability of success.

Looking more closely at Figure 1, we can see that the 306 heads of families are divided into two groups according to the trust score. Thus it can be seen that group 2 have a trust value greater than the average, and group 1 a trust value lower than the average. A total of 161 respondents belonged to group 2 and their average value for self-reliance was 4.807; the number of respondents belonging to group 1 was 145, and their average value for self-reliance was 4.4485. The 161 respondents belonging to group 2 were again divided into two groups according to the ethnic variable. The average self-reliance value for Kyrgyz people with an ethnic value of 1 was 4.775, and the average value of self-reliance was 4.921 for respondents with ethnic values of 2 and 4, that is, Uzbek and others .

Table 11 shows the average percentage for self-reliance of all respondents, divided into seven nodes.

Table 11 Basic statistics for the seven nodes

Node	N	Per cent	Mean
8	23	7.5%	4.9752
9	18	5.9%	4.9127
11	17	5.6%	4.8739
7	13	4.2%	4.8242
12	49	16.0%	4.7580
6	41	13.4%	4.6934
2	145	47.4%	4.4847

Note: Growth method: CRT; dependent variable: independence.

As can be seen, the number of respondents belonging to node 8 is 23, and their self-reliance average is 4.9752, which accounts for 7.5 per cent of the total respondents. Node 2, which has the largest number of respondents, includes 145 people, and the average self-reliance of these respondents is 4.4847, which is the lowest among all the nodes.

Table 12 shows the independent variables that have the greatest influence on the dependent variable self-reliance in order of size.

Table 12 Importance of independent variables

Independent variable	Weight	Normalized weight
trust1	.026	100.0%
Education	.004	16.0%
Occupation	.003	12.8%
Ethnic	.002	9.6%
Sex	.002	8.6%
Marital_status	.001	2.8%

Figure 2 is a graph showing the normalized weights for the independent variables. The variable that has the greatest influence on residents' self-reliance is level of trust (trust1). In other words, the higher the level of the trust respondents have in their neighbours or village leaders, the higher the self-reliance. This indicates that the social capital variable called level of trust has a strong influence on self-reliance, meaning that efforts to increase trust levels in residents are especially necessary when carrying out ODA projects in Kyrgyzstan.

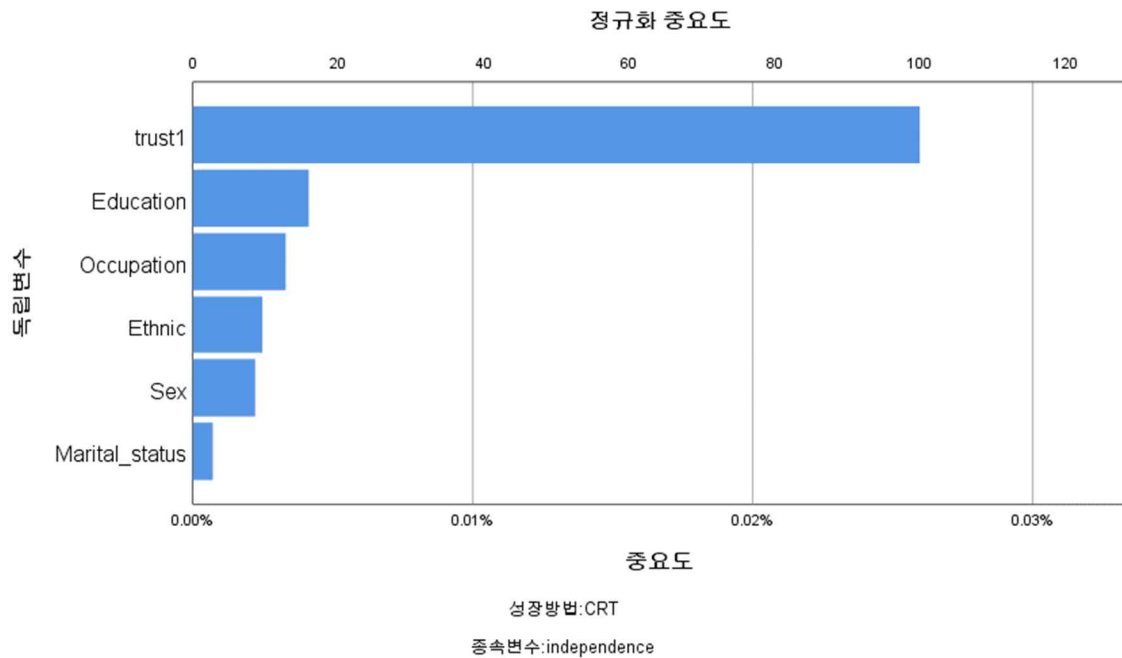

Figure 2 Normalized weight graph

Next to trust level, the variable that affects residents' self-reliance is level of education. The higher the level of education, the higher the level of self-reliance. This indicates that it is very important to raise the levels of education of local residents when selecting ODA projects for promoting the development of Kyrgyzstan.

5 Conclusion

If the aim is to raise the income levels of the people of Kyrgyzstan by carrying out ODA projects there and eventually promoting the development of that country, the most important thing to focus on is fostering the self-reliance of the people. If unconditional grant aid is merely provided without enhancing self-reliance, recipient countries only increase their dependency, and long-term national development is not achieved. Therefore, it may be temporarily important to provide free assistance to aid-recipient countries, but what really matters is to support these countries to achieve national development through self-reliance over the long term. In order to achieve this it is first necessary to gradually develop the self-reliance of the country's residents.

This study demonstrates that, as a process and means of developing this, a project aimed at increasing the level of trust among residents should be carried out first. The study shows too that self-reliance increases when a high level of trust is formed between residents, and when the level

of trust in village leaders increases. These are findings which it is important for project implementers to keep in mind when carrying out ODA projects in Kyrgyzstan in the future. There is a need to conduct similar studies in other countries to determine whether the results of this study can be applied to those also.

Acknowledgements: This work was supported by the Ministry of Education of the Republic of Korea and the National Research Foundation of Korea (NRF-2022S1A5C2A03092455).

References

Agusty, G. J., & Damayanti, S. M. (2015). The effect of foreign direct investment & official development assistance to human development index of developing countries in 2009-2013. *Journal of Business and Management*, 4(8), 882-889.

Akinkugbe, O., & Yinusa, O. (2009). ODA and human development in Sub-Saharan Africa: Evidence from panel data. In Presentation at the 14th Annual Conference On Econometric Modelling For Africa, Abuja, Nigeria (pp. 8-10).

Asiama, J. P., & Quartey, P. (2009). Foreign aid and the human development indicators in Sub-Saharan Africa. *Journal of Developing Societies*, 25(1), 57-83.

Benmamoun, M., & Lehnert, K. (2013). Financing growth: comparing the effects of FDI, ODA, and international remittances. *Journal of economic development*, 38(2), 43.

Borensztein, E., De Gregorio, J., & Lee, J. W. (1998). How does foreign direct investment affect economic growth?. *Journal of international Economics*, 45(1), 115-135.

Center for Global Development. (2018). *Quality of ODA Effectiveness*.

<https://www.cgdev.org/>

Delahais, T. & Toulemonde, J. (2012). Applying contribution analysis: Lessons from five years of practice. *Evaluation*, 18(3): 281-293.

De Mello, L. R. (1999). Foreign direct investment-led growth: evidence from time series and panel data. *Oxford Economic Papers*, 51(1), 133-151.

Elistia, E., & Syahzuni, B. A. (2018). The correlation of the human development index (HDI) towards economic growth (GDP per capita) in 10 ASEAN member countries. *Journal of Humanities and Social Studies*, 2(2), 40-46.

Funnell, S., & Rogers, P. (2011). *Purposeful program theory: Effective use of theories of change and logic models*. San Francisco, CA: Jossey Bass.

Good Neighbours International (GNI) & Korea International Cooperation Agency (KOICA). (2022). *The Integrated Rural Development Project in Kyrgyz Republic*. KOICA.

Hsiao, C., & Shen, Y.(2003). Foreign direct investment and economic growth: the importance of institutions and urbanization. *Economic development and Cultural change*, 51(4), 883-896.

Hummelbrunner, R. (2010). Beyond logframe: Critique, Variations and Alternatives. In Nobuko Fujita (ed.). *Beyond Logframe: Using Systems Concepts in Evaluation*. Issues and

Prospects of Evaluations for International Development- Series IV. FASID.

Hussain, M. (2013). *Lessons learnt from implementation of the DFID Results Framework*. DFID.

Irish Aid. (2011). *Evaluation of Country Strategy Paper 2007-2010*.

ITAD. (2012). *Evaluation of the Irish Aid Ethiopia Country Strategy 2008-2012: Contribution of a results-based management approach to strategy development*.

Jones, H. (2012). *Promoting evidence-based decision-making in development agencies*. Background Note. February 2012. Overseas Development Institute: London (February).

Jones, H. & Mendizabal, E. (2010). *Strengthening learning from research and evaluation: going with the grain*. Report to IACDI. London: Overseas Development Institute.